

Sadowsky[®] *Electronics*

MANUAL

ONBOARD BASS PREAMP (4-KNOB SYSTEM)

Master Volume / Balance / Vintage Tone Control (P/P) / Treble and Bass (stacked)

Thank you for purchasing your Sadowsky[®] Onboard Bass Preamp 4-Knob system! This preamp is designed for installation on most J-style basses with a metal control plate. On newer active J-style basses with a side jack and a battery compartment, usually no modification is required. Passive vintage style J-basses with control plates require moving the jack to the side of the bass, and routing a rear cavity large enough to contain the battery and the circuit board. If you do not have experience with wiring, soldering, routing or drilling or if you are unsure how to proceed with the installation, we strongly recommend that the installation is performed by a professional guitar technician. We recommend shielding of the control cavity and pickup cavities during the installation.

Controls

The controls are: Volume – Pan (Balance) – VTC (Vintage Tone Control) – Treble / Bass. The treble and bass controls are boost only - flat response is with the controls at their complete counterclockwise position. Do not automatically go to full treble and bass boost – start from flat response and then boost treble and bass as desired. Pull the VTC knob for total preamp bypass.

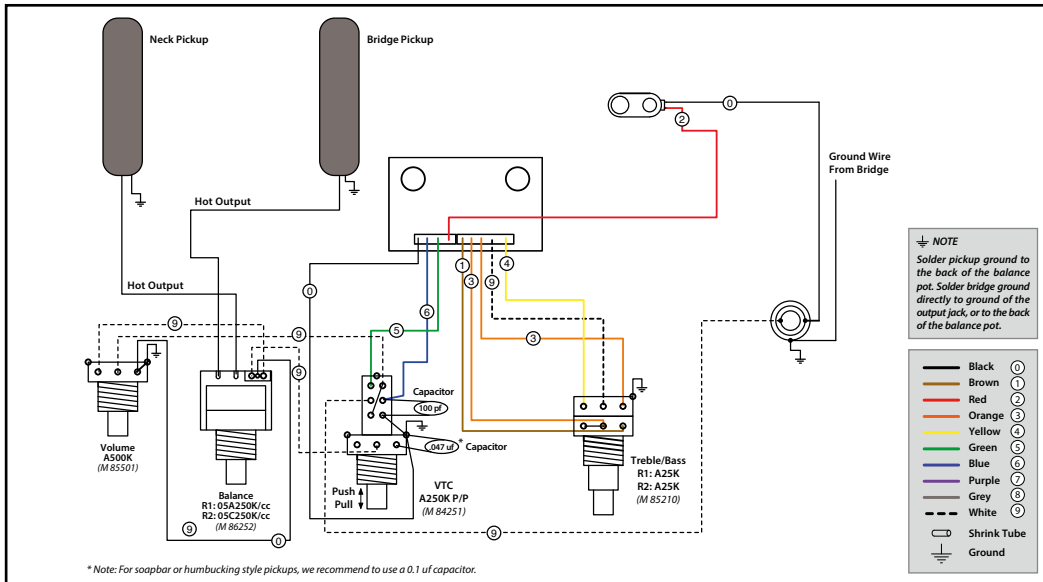

Note: The manufacturer reserves the right to change these specifications without notice.

Pickups

This system is not compatible with active pickups requiring anything else than a 250K or 500K volume or balance pot. For systems with active pickups, please custom order a parts only preamp kit and use your original volume pot.

Note: Turn the balance (pan) control counterclockwise to select the pickup in the neck position and clockwise to select the pickup in the bridge position. Since there is no 'right' or 'wrong' direction for the adjustment of the balance control and tastes are different, you can swap the pickup connections on the balance control. All that needs to be done is switching the two pickup inputs on the potentiometer.

For more information, please visit our website.

Specifications

Frequency response	5 Hz - 50 kHz
Bass control	+ 18 dB boost at 40 Hz
Treble control.....	+ 18 dB boost at 4 kHz
Total Harmonic Distortion.....	0.18% at 1 kHz
Power supply	one 9V battery
Current draw.....	9 mA
Battery life	up to 870 hours*
Input impedance	1 Mohm
Output impedance.....	1 kohm

** Note: Battery will drain whenever a cable is inserted into the output jack. Switching to bypass will not conserve battery life. Under normal use, you should expect about six months or more of battery life.*

Warwick GmbH & Co. Music Equipment KG
Gewerbepark 46 · D-08258 Markneukirchen

www.sadowskybass.de | info@sadowskybass.de | www.w-distribution.de